



868 MURRAY ROAD, DOTHAN, AL 36303

# "REDIFRAME" ONE-PIECE STEEL FRAME SYSTEM UTILIZING A THERMA-TRU OPAQUE FIBERGLASS DOOR PANEL "IMPACT"

### GENERAL NOTES

1. This product has been evaluated and is in compliance with the 7th Edition (2020) Florida Building Code (FBC) structural requirements excluding the "High Velocity Hurricane Zone" (HVHZ).
2. Product anchors shall be as listed and spaced as shown on details. Anchor embedment to base material shall be beyond wall dressing or stucco.
3. When used in areas requiring wind borne debris protection this product complies with FBC Sections 1609.1.2 & R301.2.1.2 and does not require an impact resistant covering. This product meets missile level "D" and includes Wind Zone 4 as defined in ASTM E 1996 and FBC Sections 1609.1.2.2 & R301.2.1.2.1.
4. Site conditions that deviate from the details of this drawing require further engineering analysis by a licensed engineer or registered architect.

### TABLE OF CONTENTS

SHEET #	DESCRIPTION
1	Typical elevations, design pressures & general notes
2	Steel frame cross sections & details
3	Door panel details
4	Horizontal cross sections
5	Vertical cross sections
6	Buck and frame anchoring
7	Bill of materials and components

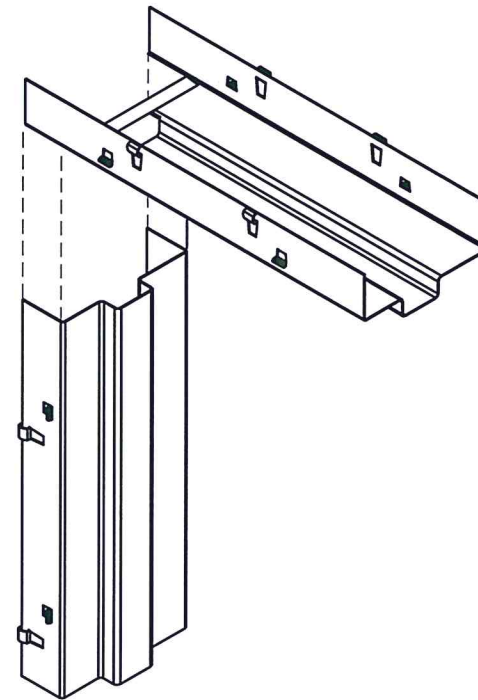

**REDIFRAME ONE-PIECE**

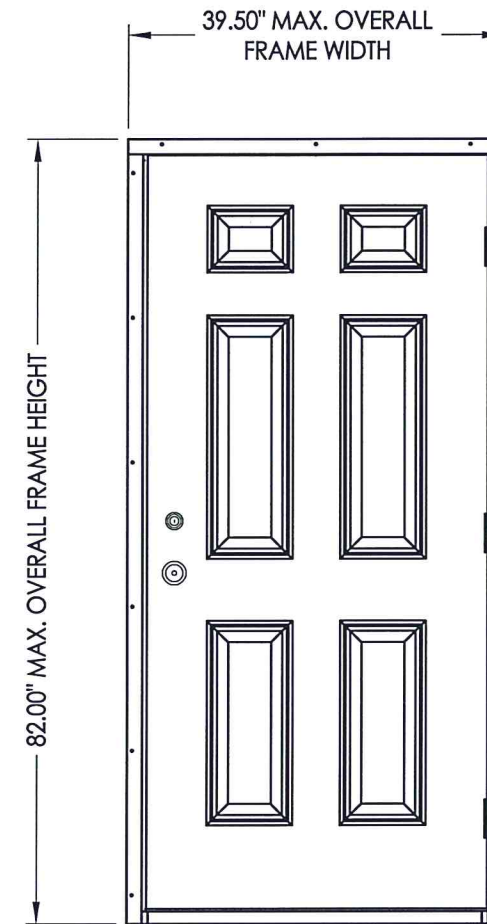

**INSWING OR OUTSWING**

OVERALL FRAME DIMENSION	DESIGN PRESSURE (PSF)	
	POSITIVE	NEGATIVE
39.50" X 82.00"	+ 66.0	- 66.0

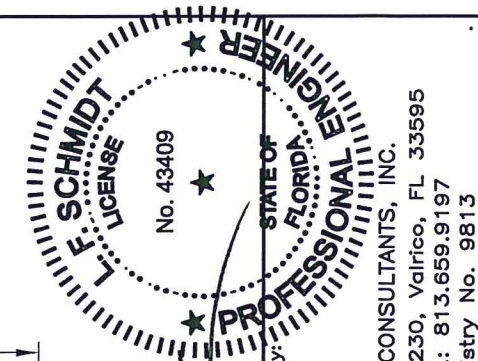

August 12, 2020  
 Documents Prepared By:  
 Lyndon F. Schmidt  
 P.E. No. 43409  
 R.W. BUILDING CONSULTANTS, INC.  
 P.O. Box 230, Valrico, FL 33595  
 Phone No.: 813.659.9197  
 FBPE Registry No. 9813

PRODUCT:	DUNBARTON REDIFRAME ONE-PIECE STEEL FRAME
PART OR ASSEMBLY:	TYPICAL ELEVATIONS, DESIGN PRESSURES & GENERAL NOTES
DATE:	3/30/15
SCALE:	N.T.S.
DWG. BY:	JK
CHK. BY:	LFS
DRAWING NO.:	FL-15366.4
SHEET	1 OF 7

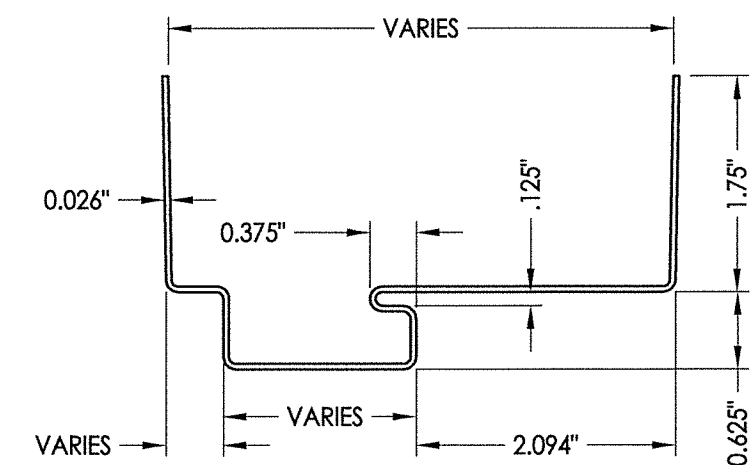
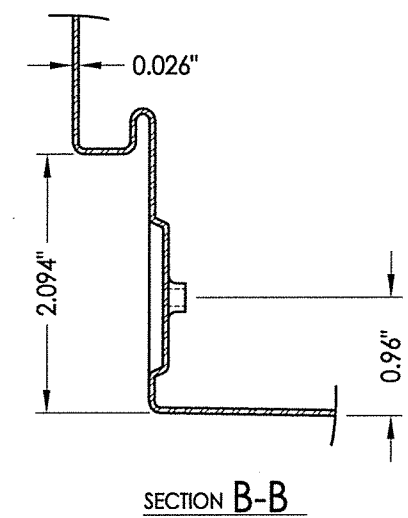
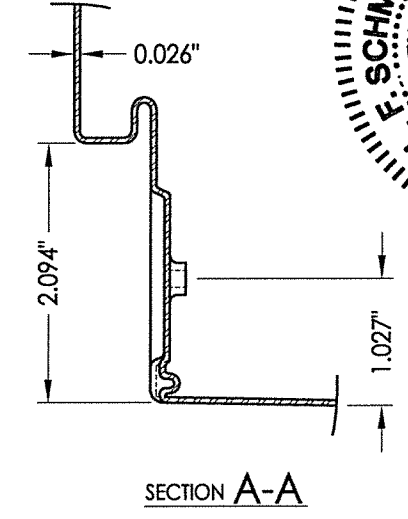
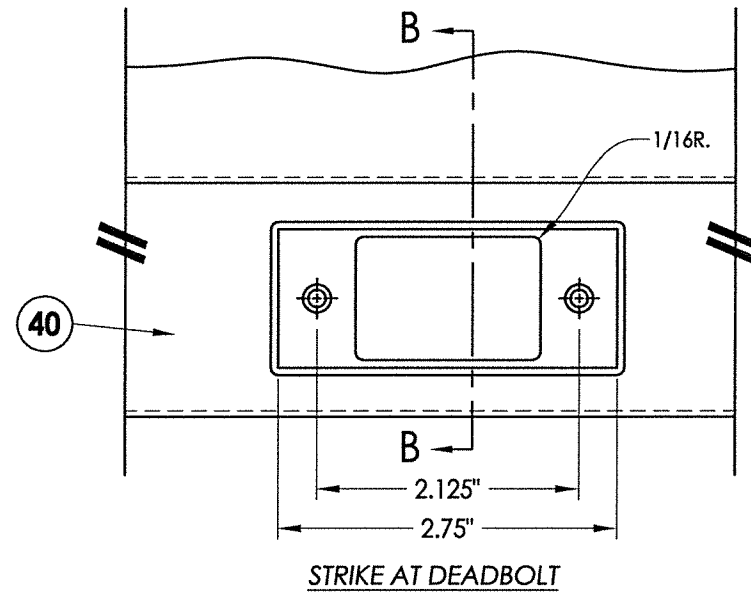
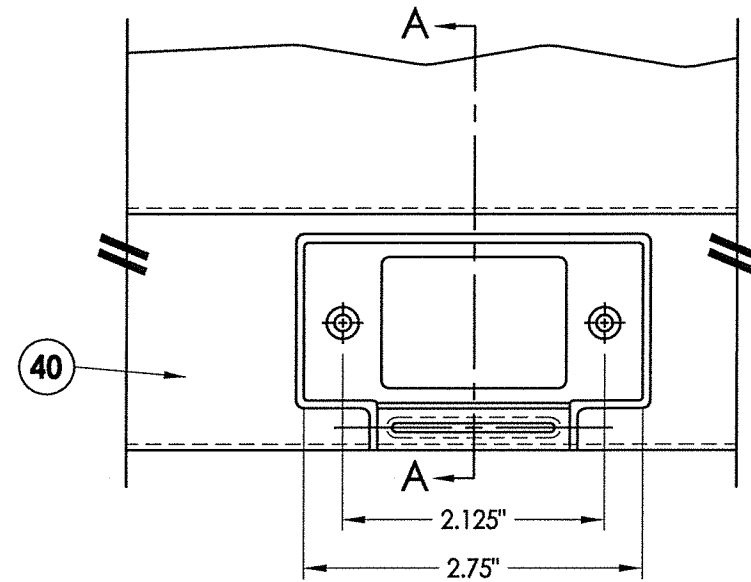
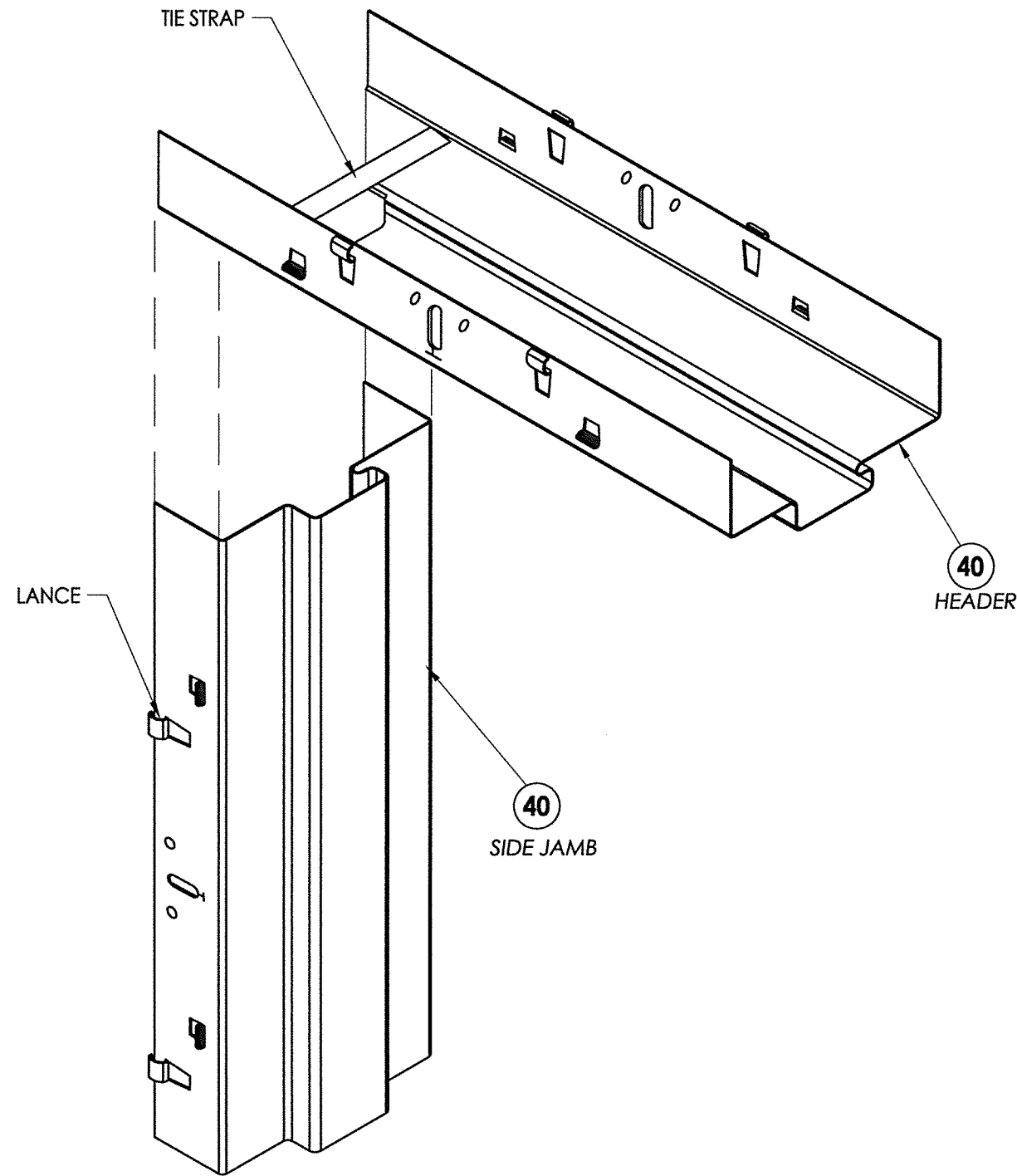

- NOTES:**
1. HEADER AND SIDE JAMB MINIMUM 22 GA. STEEL.
  2. FRAME SHOWN WITHOUT OPTIONAL STEEL TRIM CASING.
  3. NON-KERF FRAMES DO NOT MEET AIR AND WATER CRITERIA.

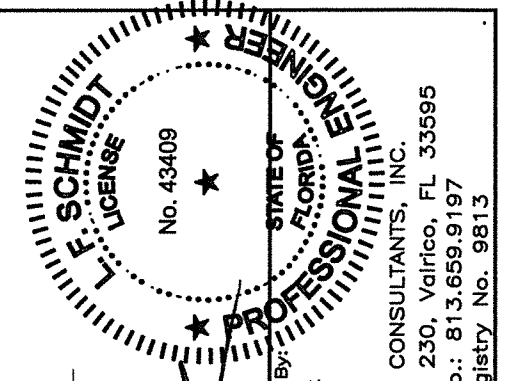

August 12, 2020  
 Documents Prepared By:  
 Lyndon F. Schmidt  
 P.E. No. 43409

**R.W.**  
 BUILDING CONSULTANTS, INC.  
 P.O. Box 230, Valrico, FL 33595  
 Phone No.: 813.659.9197  
 FBPE Registry No. 9813

PRODUCT:		DUNBARTON REDIFRAME	
PART OR ASSEMBLY:		ONE-PIECE STEEL FRAME	
STEEL FRAME CROSS SECTIONS & DETAILS			
NO.	DATE	BY	REVISIONS
2	8/12/20	DAC	
1	9/29/17	FBC	UPDATE TO 7TH ED. (2020)
		LFS	UPDATE TO 6TH ED. (2017)
DATE: 3/30/15			
SCALE: N.T.S.			
DWG. BY: JK			
CHK. BY: LFS			
DRAWING NO.: FL-15366.4			
SHEET 2 OF 7			

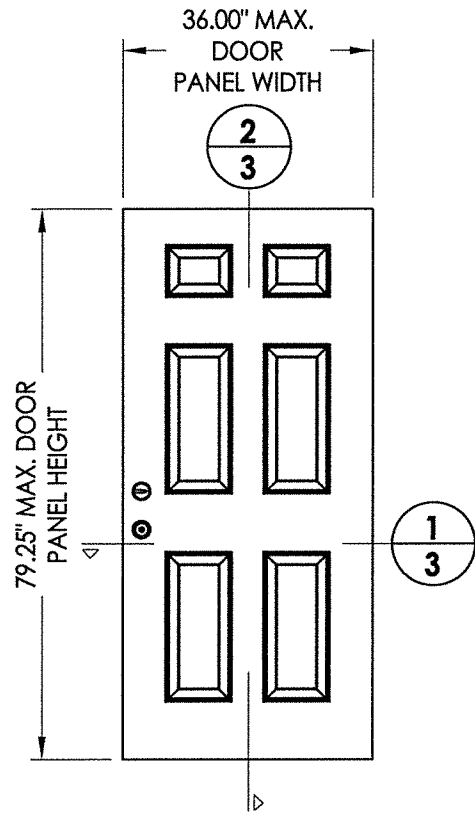

**50 FIBERGLASS DOOR PANEL**  
THERMA-TRU  
Fiber classic

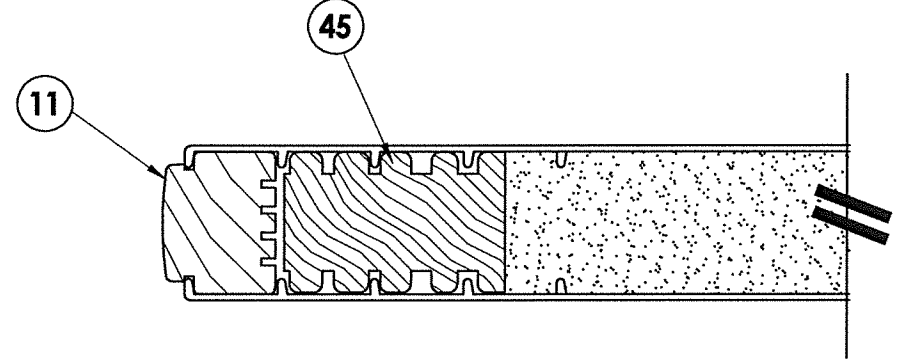

**1 HORIZONTAL CROSS SECTION**

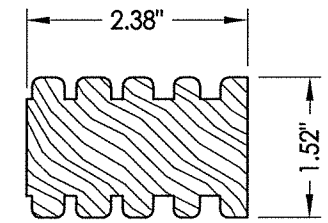

**45 LOCK BLOCK**

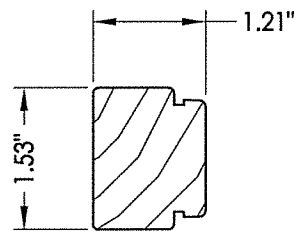

**12 HINGE STILE**

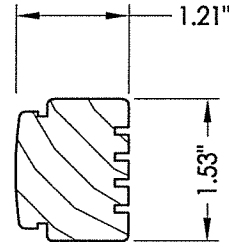

**11 LATCH STILE**

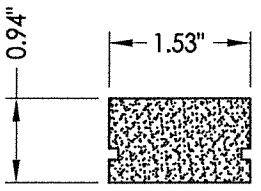

**14 TOP RAIL**

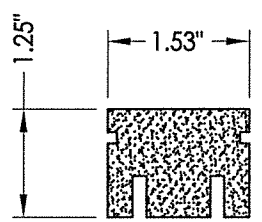

**13 BOTTOM RAIL**

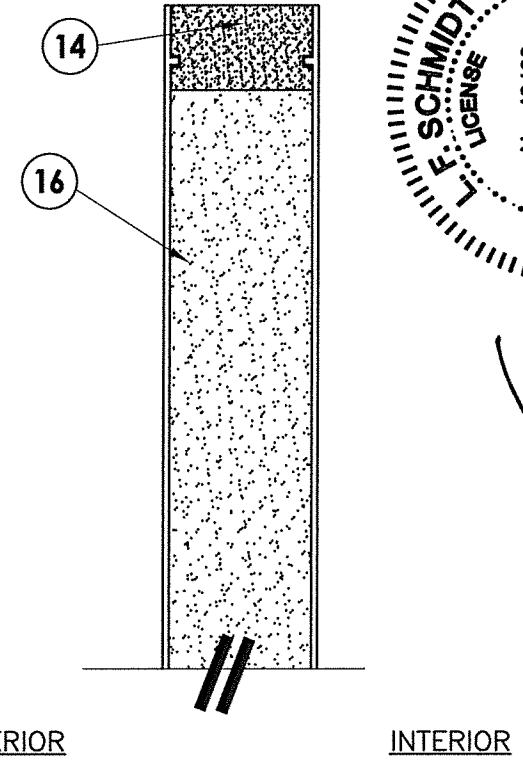
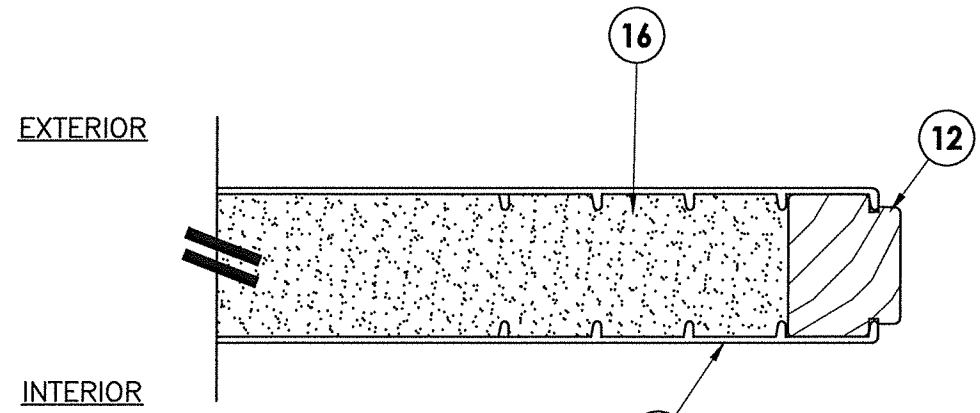

**2 VERTICAL CROSS SECTION**

August 12, 2020  
 Documents Prepared By:  
 Lyndon F. Schmidt  
 P.E. No. 43409  
 R.W. BUILDING CONSULTANTS, INC.  
 P.O. Box 230, Valrico, FL 33595  
 Phone No.: 813.659.9197  
 FBPE Registry No. 9813

PRODUCT:		DUNBARTON REDIFRAME ONE-PIECE STEEL FRAME	
PART OR ASSEMBLY:		DOOR PANEL DETAILS	
NO.	DATE	BY	REVISIONS
2	8/12/20	FBC	UPDATE TO 7TH ED. (2020)
1	9/29/17	FBC	UPDATE TO 6TH ED. (2017)

DATE: 3/30/15  
 SCALE: N.T.S.  
 DWG. BY: JK  
 CHK. BY: LFS  
 DRAWING NO.: FL-15366.4  
 SHEET 3 OF 7

\\dc01\wbc\Clients\Dunbarton Permanent\A - Florida Product Approvals\FL-15366 - Swinging Ext Doors - Rediframe (Steel)\C - Drawings\FL-15366 (2020)\FL-15366.4-5.dwg

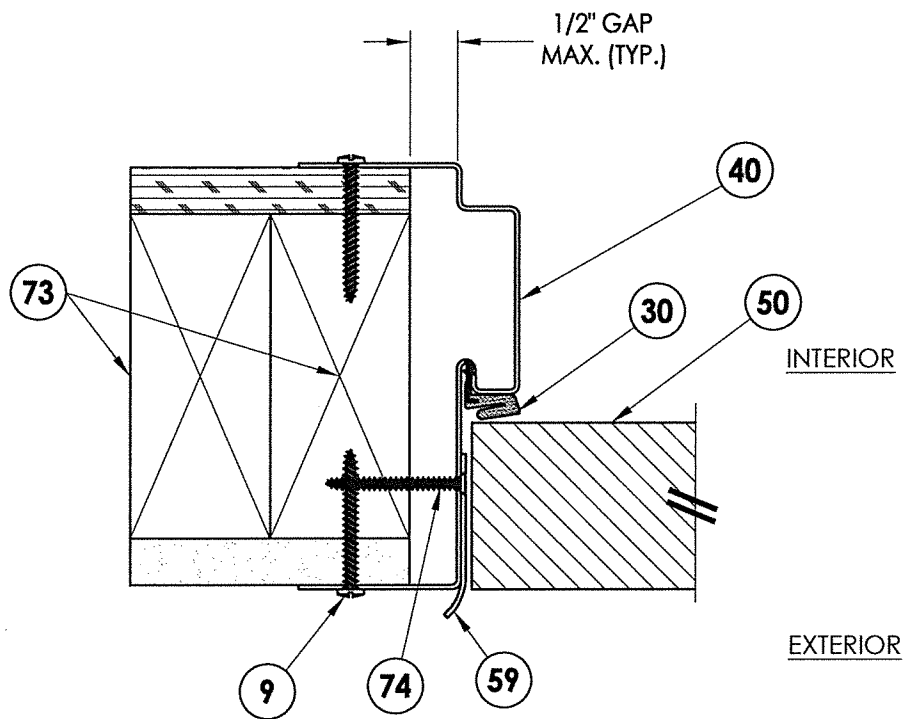

**1** **HORIZONTAL CROSS SECTION**  
**4** Shown w/ stud construction  
 Outswing shown (Inswing similar)

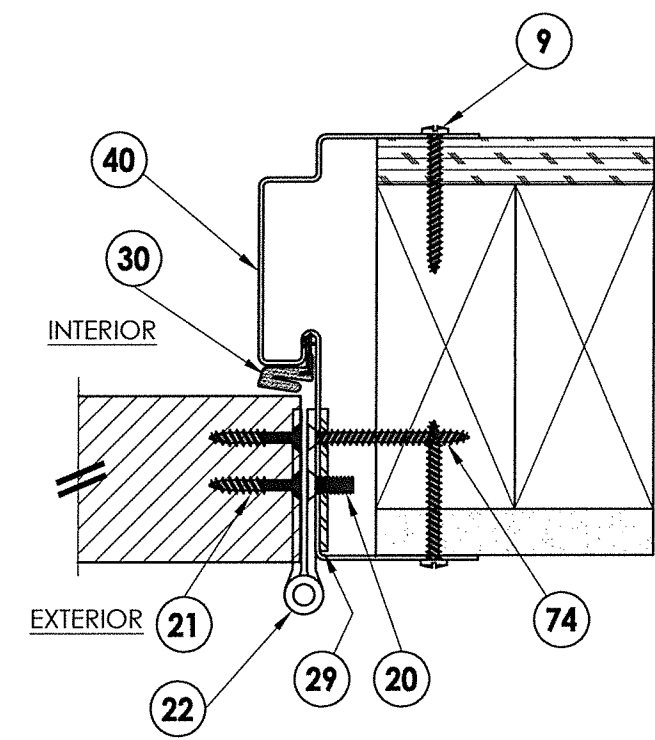
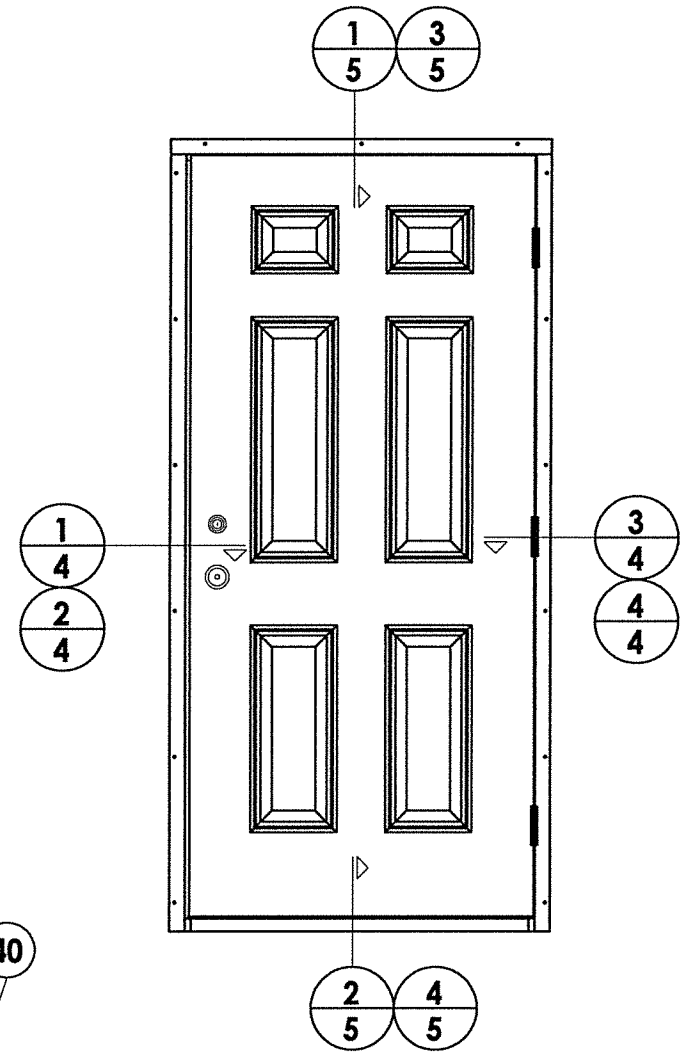

**3** **HORIZONTAL CROSS SECTION**  
**4** Shown w/ stud construction  
 Outswing shown (Inswing similar)

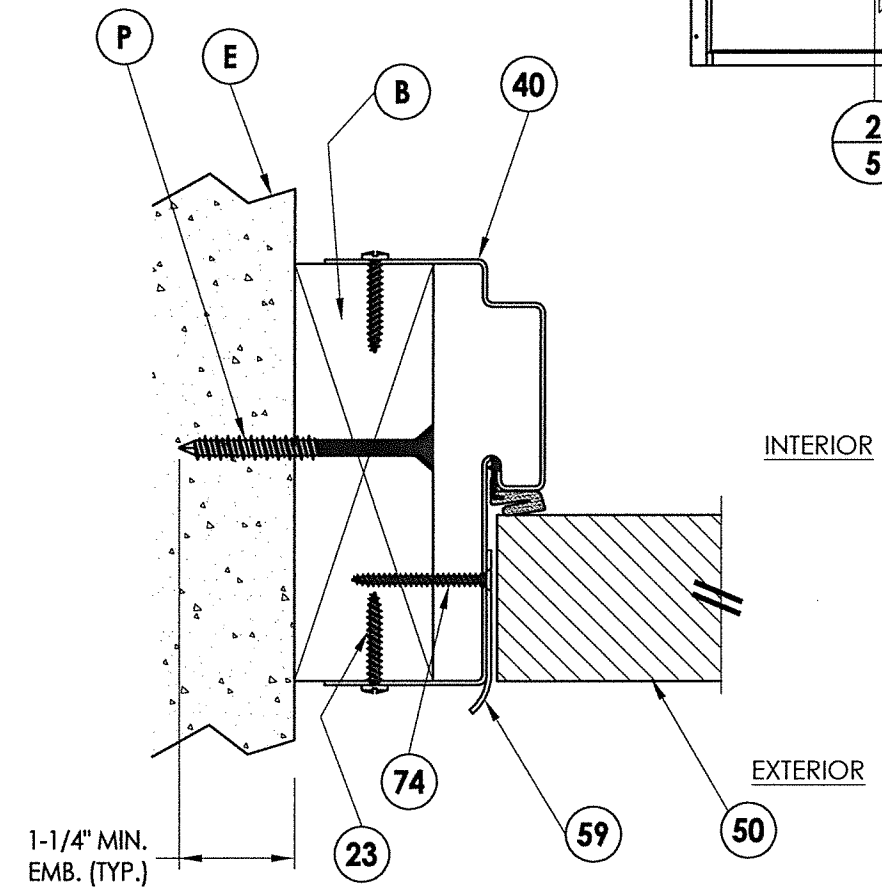

**2** **HORIZONTAL CROSS SECTION**  
**4** 2X wood buck @ latch  
 Outswing shown (Inswing similar)

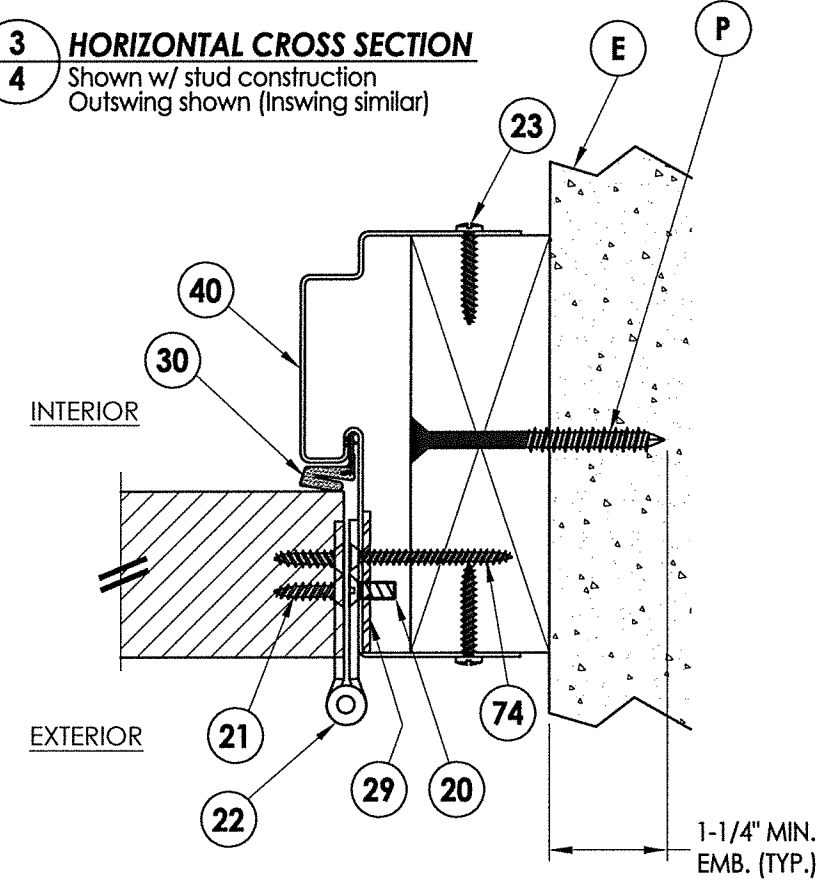

**4** **HORIZONTAL CROSS SECTION**  
**4** 2X wood buck @ hinge  
 Outswing shown (Inswing similar)

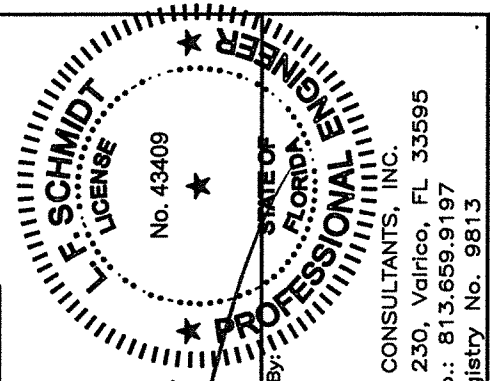

August 12, 2020  
 Documents Prepared By:  
 Lyndon F. Schmidt  
 P.E. No. 43409  
 RW BUILDING CONSULTANTS, INC.  
 P.O. Box 230, Valrico, FL 33595  
 Phone No.: 813.659.9197  
 FBPE Registry No. 9813

PRODUCT:		DUNBARTON REDIFRAME	
		ONE-PIECE STEEL FRAME	
PART OR ASSEMBLY:		HORIZONTAL	
		CROSS SECTIONS	
NO.	DATE	BY	REVISIONS
2	8/12/20	FBC	UPDATE TO 7TH ED. (2020)
1	9/29/17	FBC	UPDATE TO 6TH ED. (2017)
		DAC	
		LFS	
DATE: 3/30/15			
SCALE: N.T.S.			
DWG. BY: JK			
CHK. BY: LFS			
DRAWING NO.: FL-15366.4			
SHEET 4 OF 7			



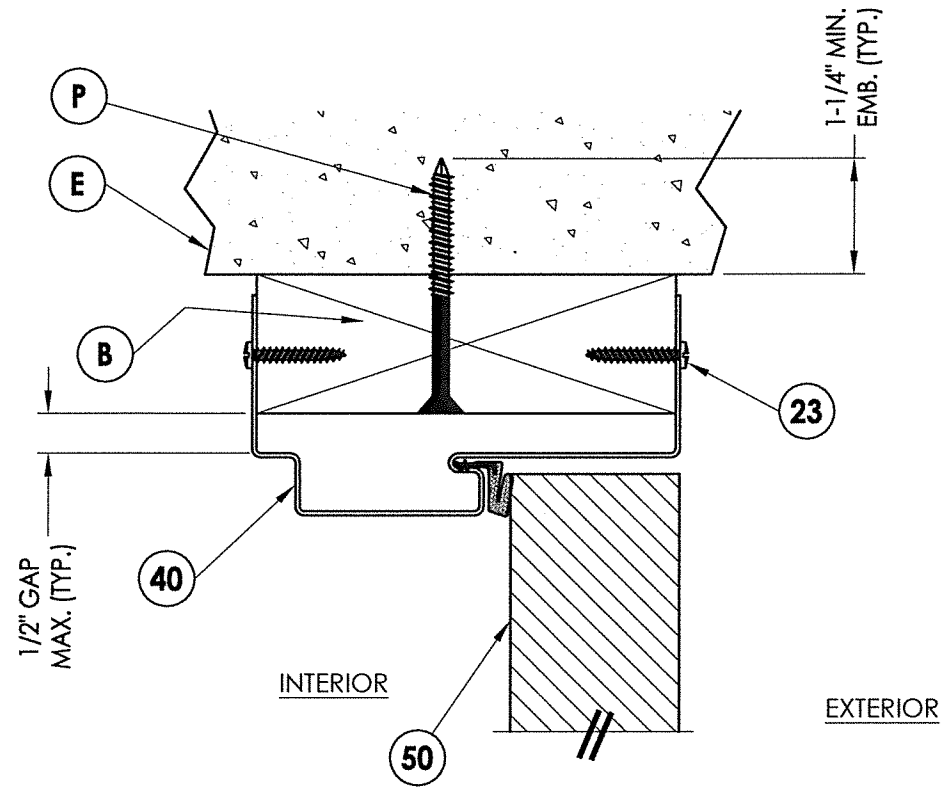

**1** VERTICAL CROSS SECTION  
**5** Shown w/ wood buck  
 Outswing shown (inswing similar)

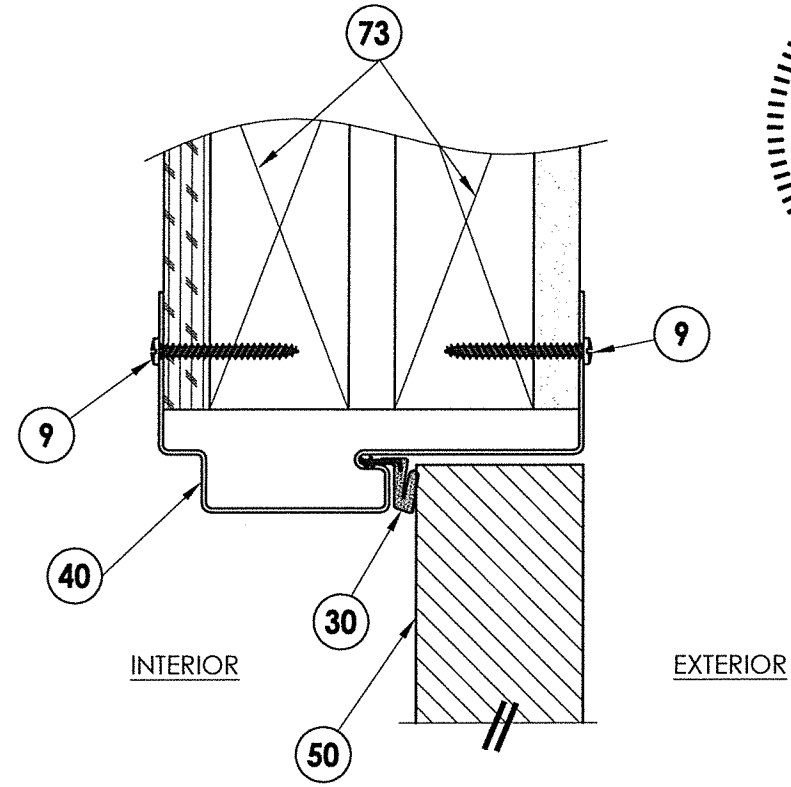

**3** VERTICAL CROSS SECTION  
**5** Shown w/ stud construction  
 Outswing shown (inswing similar)

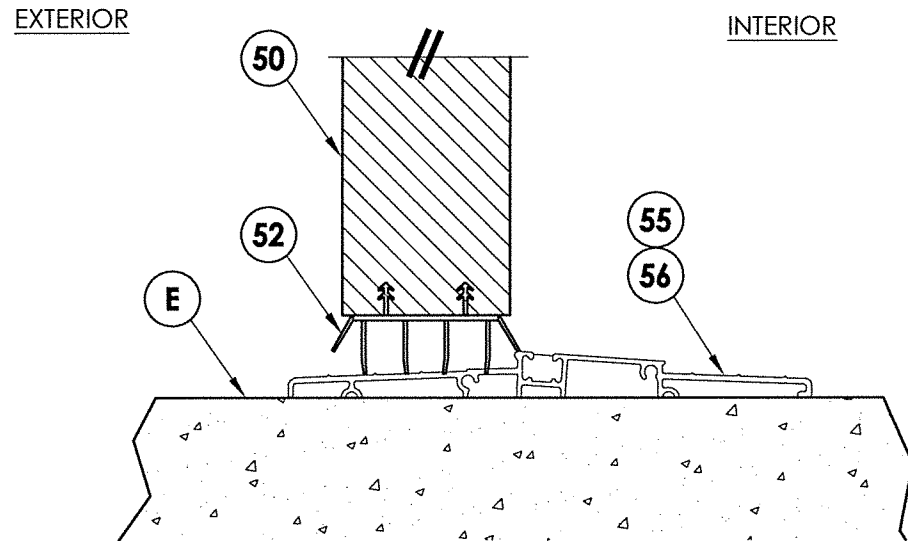

**2** VERTICAL CROSS SECTION  
**5** Outswing Sill

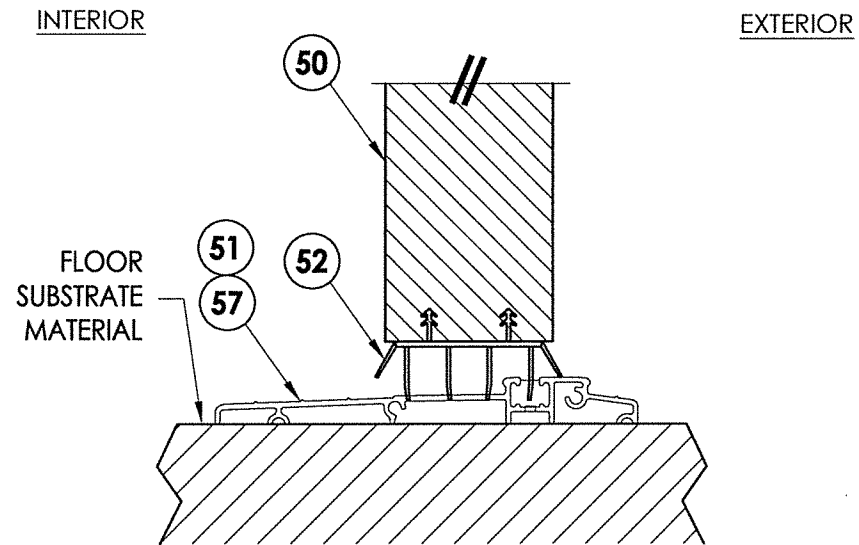

**4** VERTICAL CROSS SECTION  
**5** Inswing Sill

August 12, 2020  
 Documents Prepared By:  
 Lyndon F. Schmidt  
 P.E. No. 43409

**L. F. SCHMIDT**  
 LICENSE  
 No. 43409  
 STATE OF FLORIDA  
 PROFESSIONAL ENGINEER

*R.W.*  
 BUILDING CONSULTANTS, INC.  
 P.O. Box 230, Valrico, FL 33595  
 Phone No.: 813.659.9197  
 FBPE Registry No. 9813

PRODUCT:		DUNBARTON REDIFRAME ONE-PIECE STEEL FRAME	
PART OR ASSEMBLY:		VERTICAL CROSS SECTIONS	
NO.	DATE	BY	REVISIONS
2	8/12/20	DAC	UPDATE TO 7TH ED. (2020) FBC
1	9/29/17	LFS	UPDATE TO 6TH ED. (2017) FBC
DATE: 3/30/15			
SCALE: N.T.S.			
DWG. BY: JK			
CHK. BY: LFS			
DRAWING NO.: FL-15366.4			
SHEET 5 OF 7			

\\dc01\rvbc\Clients\Dunbarton Permanent\VA - Florida Product Approvals\FL-15366 - Swinging Ext Doors - Rediframe (Steel)\C - Drawings\FL-15366 (2020)\FL-15366.4-5.dwg

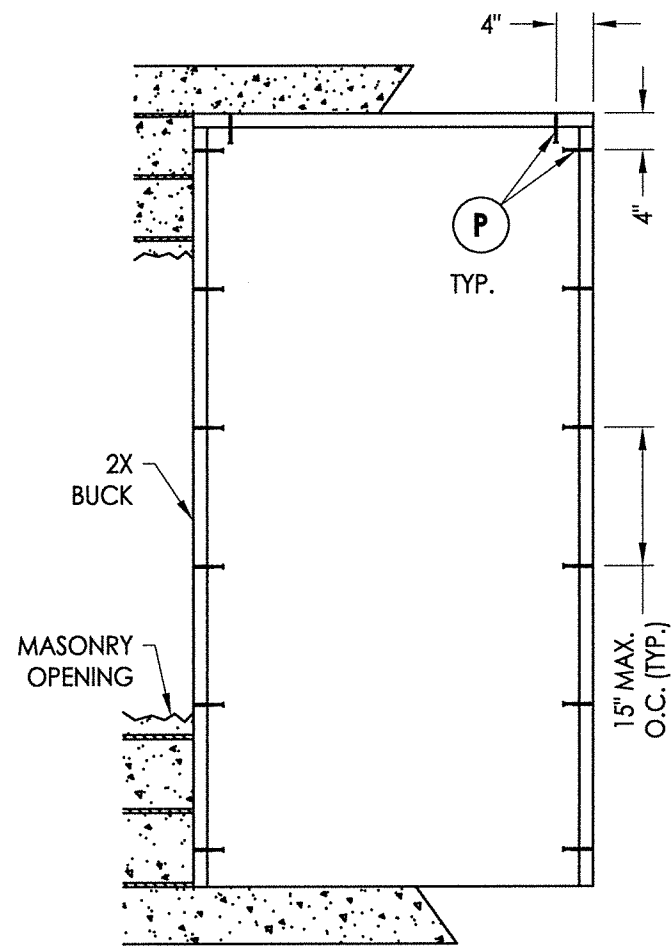

**BUCK ANCHORING**

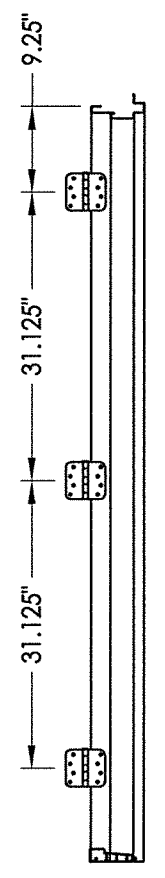

**HINGE JAMB**

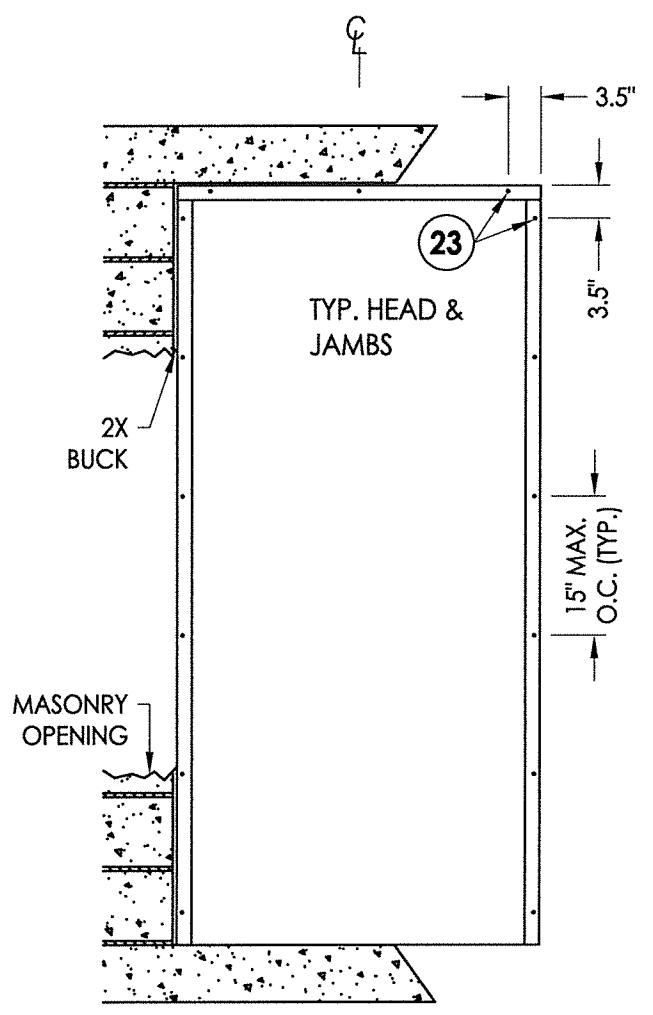

**FRAME ANCHORING  
2X MASONRY**

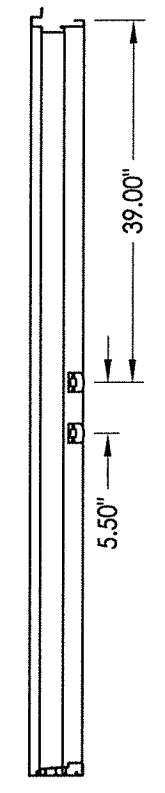

**STRIKE JAMB**

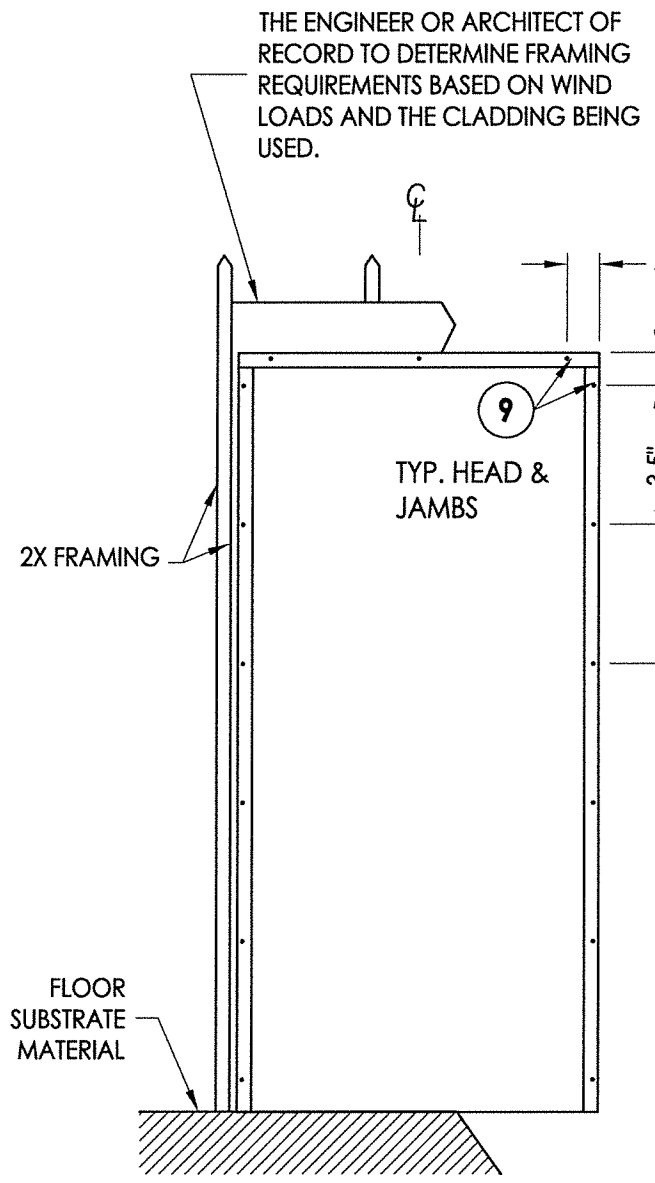

**FRAME ANCHORING  
STUD CONSTRUCTION**

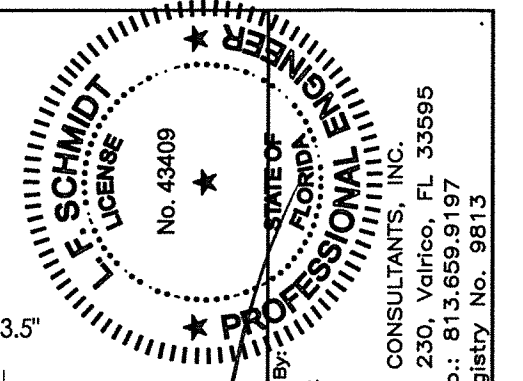

August 12, 2020  
 Documents Prepared By:  
 Lyndon F. Schmidt  
 P.E. No. 43409  
 R.W. BUILDING CONSULTANTS, INC.  
 P.O. Box 230, Valrico, FL 33595  
 Phone No.: 813.659.9197  
 FBPE Registry No. 9813

- CONCRETE ANCHOR NOTES:**
- Concrete anchor locations at the corners may be adjusted to maintain the min. edge distance to mortar joints.
  - Concrete anchor locations noted as "MAX. ON CENTER" must be adjusted to maintain the min. edge distance to mortar joints, additional concrete anchors may be required to ensure the "MAX. ON CENTER" dimension are not exceeded.
  - Concrete anchor table:

ANCHOR TYPE	ANCHOR SIZE	MIN. EMBEDMENT	MIN. CLEARANCE TO MASONRY EDGE	MIN. CLEARANCE TO ADJACENT ANCHOR
ITW TAPCON®	1/4"	1-1/4"	2"	4"
DeWALT ULTRACON+®	1/4"	1-1/4"	1"	4"

- WOOD SCREW INSTALLATION NOTES:**
- Maintain a minimum 5/8" edge distance, 1" end distance, & 1" o.c. spacing of wood screws to prevent the splitting of wood.

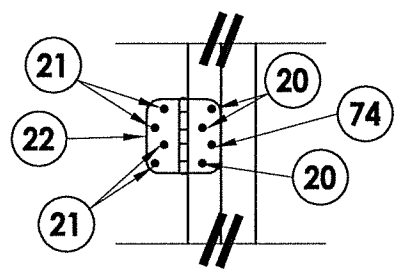

**HINGE DETAIL**

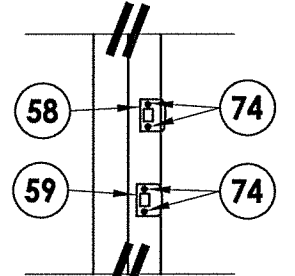

**STRIKE DETAIL**

PRODUCT:	DUNBARTON REDIFRAME ONE-PIECE STEEL FRAME	
PART OR ASSEMBLY:	BUCK & FRAME ANCHORING	
NO.	DATE	BY
2	8/12/20	FBC
1	9/29/17	FBC
REVISIONS		
DATE:	3/30/15	
SCALE:	N.T.S.	
DWG. BY:	JK	
CHK. BY:	LFS	
DRAWING NO.:	FL-15366.4	
SHEET	6 OF 7	

\\dc01\vwbc\Clients\Dunbarton Permanent\A - Florida Product Approvals\FL-15366 - Swinging Ext Doors - Rediframe (Steel)\C - Drawings\FL-15366 (2020)\FL-15366.4-5.dwg

BILL OF MATERIALS		
ITEM	DESCRIPTION	MATERIAL
B	2X BUCK (SG >= 0.55)	WOOD
C	1/4" MAX. SHIM SPACE	-
E	MASONRY - 3,000 PSI MIN. CONCRETE CONFORMING TO ACI 301 OR HOLLOW BLOCK CONFORMING TO ASTM C90 OR ASTM A653 STEEL	CONCRETE
P	1/4" X 2-3/4" DeWALT OR ITW PFH CONCRETE SCREW	STEEL
9	#8 X 1-1/2" PPH SMS (7/8" MIN. EMBEDMENT)	STEEL
11	LATCH STILE	WOOD
12	HINGE STILE	WOOD
13	BOTTOM RAIL	WOOD/COMP.
14	TOP RAIL	WOOD/COMP.
15	DOOR SKIN (MIN. 0.090" THK)	FIBERGLASS
16	FOAM CORE (POLYURETHANE)	POLYURETHANE
20	10-24 X 1/2" FLAT HEAD SCREW	STEEL
21	#9 X 1" PFH WOOD SCREW	STEEL
22	HINGE 4" X 4"	STEEL
23	#8 X 1" PH SMS (7/8" MIN. EMBEDMENT)	STEEL
29	JAMB HINGE REIN. 14 GA. 4" x 4" x 1.53" (.075" GALV. STEEL) BY DUNBARTON FRO0505	STEEL
30	COMPRESSION WEATHERSTRIPPING QLON QDS 650 BY SCHLEGEL	FOAM
40	REDIFRAME JAMB 22 GA. MIN. .026" GALV. STEEL BY DUNBARTON	STEEL
45	LOCK BLOCK	LVL
50	FIBERGLASS DOOR PANEL (THERMA-TRU "FIBER-CLASSIC")	-
51	INSWING HIGH DAM THRESHOLD BY ENDURA ZAI4566	ALUMINUM
52	DOOR BOTTOM SWEEP	VINYL
55	OUTSWING BUMP THRESHOLD 4.563" x 1.446" BY ENDURA ZFOB4566F	ALUMINUM
56	OUTSWING ADA THRESHOLD BY ENDURA ZHCO5622	ALUMINUM
57	INSWING ADA THRESHOLD BY ENDURA ZHCI4562	ALUMINUM
58	STRIKE PLATE - DEADBOLT	STEEL
59	STRIKE PLATE - LATCHBOLT	STEEL
60	KWIKSET SERIES (660) DEADBOLT	STEEL
61	KWIKSET SERIES PASSAGE LOCK	STEEL
73	2X FRAMING (SG >= 0.42)	WOOD
74	#8 x 1-3/4" PFH SMS	STEEL

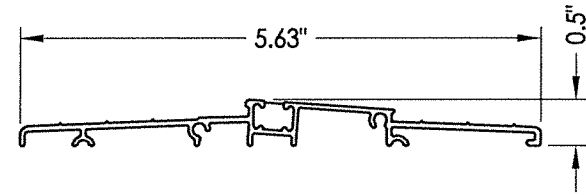

56 OUTSWING THRESHOLD

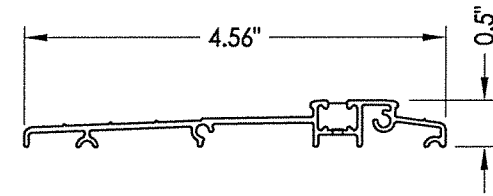

57 INSWING THRESHOLD

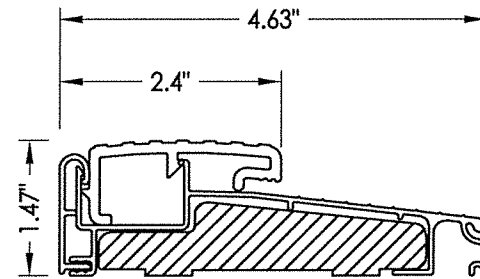

55 OUTSWING THRESHOLD

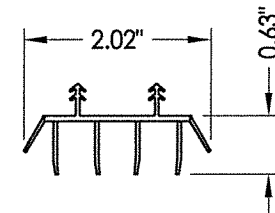

52 SWEEP

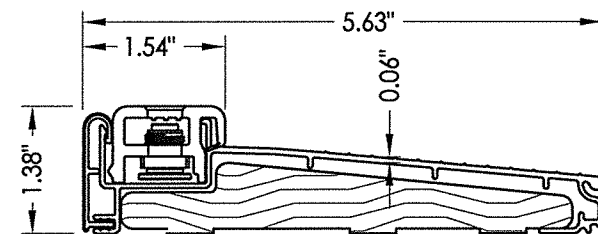

51 INSWING THRESHOLD

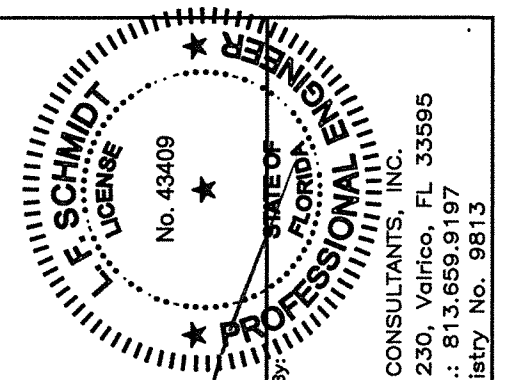

August 12, 2020

Documents Prepared By:  
Lyndon F. Schmidt  
P.E. No. 43409

**R.W.**  
BUILDING CONSULTANTS, INC.  
P.O. Box 230, Valrico, FL 33595  
Phone No.: 813.659.9197  
FBPE Registry No. 9813

PRODUCT:  
DUNBARTON REDIFRAME  
ONE-PIECE STEEL FRAME

PART OR ASSEMBLY:  
BILL OF MATERIALS  
& COMPONENTS

NO.	DATE	REVISIONS
2	8/12/20	UPDATE TO 7th ED. (2020) FBC
1	9/29/17	UPDATE TO 6TH ED. (2017) FBC

DATE: 3/30/15

SCALE: N.T.S.

DWG. BY: JK

CHK. BY: LFS

DRAWING NO.:

FL-15366.4

SHEET 7 OF 7